



RWE120 combines the compact chassis of a powered stacker with the flexibility of a reach truck. Handles different types of pallets but requires the minimum amount of working space.



Technical Details		RWE120
Rated capacity	kg	1200
Load centre	mm	600
Max. axle load drive wheel, with rated load		
mast rear, tilt down/up	kg	880/910
mast forward, tilt down/up	kg	210/230
Max. axle load drive wheel, without rated load		
mast rear, tilt down/up	kg	700/720
mast forward, tilt down/up	kg	765/780
Max. axle load support arm wheels, with rated load		
mast rear, tilt down/up	kg	830/820
mast forward, tilt down/up	kg	1330/1325
Max. axle load support arm wheels, without rated load		
mast rear, tilt down/up	kg	260/250
mast forward, tilt down/up	kg	450/445
Mast tilt forward/backward	°	1.3/1.6
Travel speed, without/with rated load	km/h	6/5
Lift speed, without/with rated load	m/s	0.24/0.15 <sup>1)</sup>
Lowering speed, without/with rated load	m/s	0.40/0.50 <sup>1)</sup>
Gradient, without/with rated load	%	10/8
Service-/parking brake		2 stage electromagnetic brake
Drive motor/Intermittent rating	kW/%	1.4/60
Lift motor/Intermittent rating	kW/%	3.1/20
Steering system		steering arm
Speed control		transistor, stepless
Steering arc	°	180

Dimensions, mm		RWE120
x	Back of fork to wheel centre	640 <sup>2)</sup>
	Support arm wheels, Vulkollan	Ø 140x60
	Drive wheel, Vulkollan	Ø 215
h <sub>7</sub>	Platform height	230
l <sub>24</sub>	Platform length	530
h <sub>14</sub>	Height of handle in neutral pos., without/with platform	1525/1295
h <sub>8</sub>	Height of support arm	150
h <sub>13</sub>	Height of lowered fork	40
l <sub>2</sub>	Truck length incl. fork face, without/with platform up/down	1025/1190/1555 <sup>3)</sup>
l <sub>7</sub>	Truck length excl. fork	1748 <sup>3)</sup>
b <sub>1</sub>	Chassis, width	850
b <sub>2</sub>	Width across support arms, min./max.	900/1085
s	Fork thickness	40
e	Fork width	100
l	Fork length	1150
b <sub>5</sub>	Width across fork, min./max.	250—620/250—773
b <sub>4</sub>	Width between support arms, min./max.	665/850
l <sub>4</sub>	Reach movement	810
m <sub>1</sub>	Floor clearance under mast	45 <sup>4)</sup>
A <sub>st</sub>	Aisle width, without/platform up/down	2570/2735/3090 <sup>5)</sup>
W <sub>a</sub>	Turning radius, without/with platform up/down	1680/1848/2200 <sup>5)</sup>

Mast, mm			Duplex Tele			Duplex Hi-Lo					Triplex Hi-Lo				
h <sub>23</sub>	Total lift height	mm	2400	2800	3350	2400	2900	3350	3750	4150	3600	3750	4150	4500	4800
h <sub>1</sub>	Height of mast, min.	mm	1737	1937	2212	1737	1987	2212	2422	2622	1765	1830	1948	2065	2165
h <sub>2</sub>	Free lift	mm	—	—	—	1268	1518	1743	1943	2143	1291	1341	1476	1592	1692
h <sub>4</sub>	Height of mast, max.	mm	2917	3317	3867	2917	3417	3867	4277	4677	4120	4270	4670	5021	5321
	Weight without battery <sup>6)</sup>	kg	1222	1242	1272	1222	1247	1272	1292	1312	1377	1392	1407	1437	1447
	Battery (5h discharge), min./max.	V/Ah	276—300												
	Battery weight, min./max.	kg	240—300												

1) Based on Triplex mast

2) Based on Triplex mast; Duplex mast +20 mm

3) Based on Triplex mast; Duplex mast -20 mm

4) 15 mm under studs

5) Mast rear

6) b<sub>2</sub> 1085 mm = +50 kg

For sideshift = +100 kg

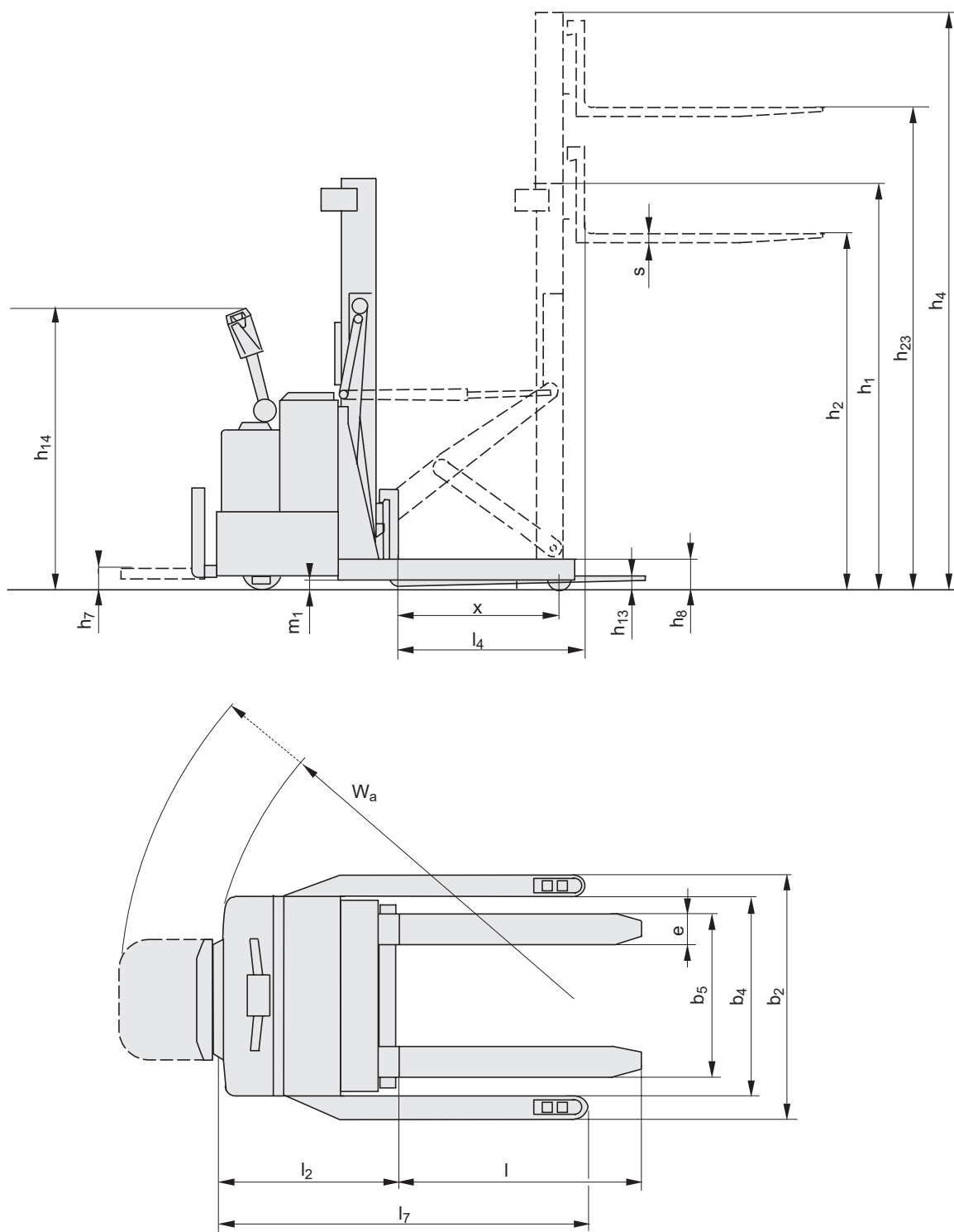

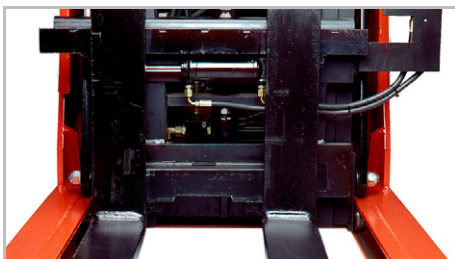
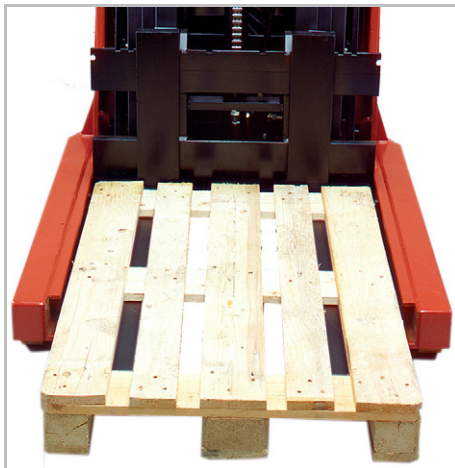

- The small compact stacker reach truck, that is available in lift heights up to 4800 mm, offers safe load handling for a variety of pallets. The compact dimensions make the truck especially useful in confined areas.
- The truck is available in two chassis widths, where the wide version straddles a Euro-pallet.
- Hydraulic mast tilt offers additional safety in load handling.
- Optional side shift for fine positioning of load reduces the need for movements of the complete truck. This is extraordinarily profitable when used in confined areas.
- Servo assisted steering is optional and provides effortless steering which is very effective in narrow spaces and uneven floors.

Truck features	RWE120
Adjustable fork width	S
Choice of chassis widths	O
Tilting mast	S
Controls and instrument	
Fingertip controls	S
Hour meter	O
Power/Electronic steering	O
Sideshift	O
Tiller arm steering	S
Driving features	
180° steering	S
Electronic braking system	S
Electronic regenerative brakes	S
Electronic speed control	S
Flip-down driver platform	S
Safety features	
Automatic parking brake	S
Clear-view mast	S
Emergency collision button	S
Emergency cut-off	S
Load support	O
Parking brake	S
Maintenance features	
Easy access for maintenance	S
Fault diagnosis facility	S
Battery management features	
Battery status indicator	O

S = Standard feature

O = Optional feature

— = Not available